



# KIESELMANN

FLUID PROCESS GROUP

Translation of the original

## Operating instruction

### Double seat valves

Type 567x

Seal material: EPDM, HNBR



**KIESELMANN GmbH**

Paul-Kieselmann-Str. 4-10  
D - 75438 Knittlingen

 +49(0) 7043 371-0 •  +49(0) 7043 371-125  
[www.kieselmann.de](http://www.kieselmann.de) • [info@kieselmann.de](mailto:info@kieselmann.de)

---

Copyright: © KIESELMANN FLUID PROCESS GROUP

## Table of contents

<b>1</b>	<b>General informations</b>	<b>4</b>
1.1	Informations for your safety	4
1.2	Marking of security instructions	4
1.3	General designated use	4
1.4	Personnel	4
1.5	Modifications, spare parts, accessories	5
1.6	General instructions	5
<b>2</b>	<b>Safety instructions</b>	<b>6</b>
2.1	Intended use	6
2.2	General notes	6
2.3	General safety instructions	6
<b>3</b>	<b>Delivery, transport and storage</b>	<b>8</b>
3.1	Delivery	8
3.2	Transport	8
3.3	Storage	8
<b>4</b>	<b>Function and operation</b>	<b>9</b>
4.1	Description of function	9
4.2	Control system and position indicator	9
4.3	Pneumatic valve activation	10
<b>5</b>	<b>Commissioning, service and maintenance</b>	<b>11</b>
5.1	Commissioning	11
5.1.1	Installation instructions	11
5.1.2	General welding guidelines	11
5.1.3	ATEX - Guidelines	11
5.2	Service	11
5.2.1	Maintenance table	12
5.3	Cleaning	12
<b>6</b>	<b>Technical data</b>	<b>13</b>
6.1	Double seat valve Type 567x	13
6.2	KV - value	13
6.3	Cleaning flow rate	13
6.4	Torques	14
<b>7</b>	<b>Disassembly and assembly</b>	<b>15</b>
7.1	Disassembly	15
7.1.1	Assembly valve insert VE	16
7.1.2	Replacement wear parts	16
7.2	Assembly	20
7.2.1	Seals (D4)	23
7.2.2	Shaft sealing	24
<b>8</b>	<b>Drawings and dimensions</b>	<b>25</b>
8.1	Double seat valve	25
8.1.1	Dimensions	28
8.2	Control units	29
<b>9</b>	<b>Wearing parts</b>	<b>30</b>
9.1	Double seat valve Type 567x DN25 / OD 1 Inch	30
9.2	Double seat valve Type 567x DN40 - DN150 / 1,5" - 4"	33
<b>10</b>	<b>Classification</b>	<b>39</b>
10.1	Structure of Order Number	39
<b>11</b>	<b>Appendix</b>	<b>41</b>
11.1	Declaration of incorporation	41

# 1 General informations

## 1.1 Informations for your safety

We are pleased that you have decided for a high-class KIESELMANN GmbH product. With correct application and adequate maintenance, our products provide long time and reliable operation.





Before installation and initiation, please carefully read this instruction manual and the security advices contained in it. This guarantees reliable and safe operation of this product and your plant respectively. Please note that an incorrect application of the process components may lead to great material damages and personal injury.

In case of damages caused by non observance of this instruction manual, incorrect initiation, handling or external interference, guarantee and warranty will lapse!

Our products are produced, mounted and tested with high diligence. However, if there is still a reason for complaint, we will naturally try to give you entire satisfaction within the scope of our warranty. We will be at your disposal also after expiration of the warranty. In addition, you will also find all necessary instructions and spare part data for maintenance in this instruction manual. If you don't want to carry out the maintenance by yourself, our KIESELMANN GmbH - service team will naturally be at your disposal.

## 1.2 Marking of security instructions

Hints are available in the chapter "safety instructions" or directly before the respective operation instruction. The hints are highlighted with a danger symbol and a signal word. Texts beside these symbols have to be read and adhered to by all means. Please continue with the text and with the handling at the valve only afterwards.

Symbol	Signal word	Meaning
	DANGER	Imminent danger which will result severe personal injury or death.
	WARNING	Imminent danger which may result severe personal injury or death.
	CAUTION	Dangerous situation which may cause slight personal injury or material damages.
	NOTICE	An harmful situation which may result in damages of the product itself or of adjacent vicinity.
	INFORMATION	Marks application hints and other information which is particularly useful.

## 1.3 General designated use

The fitting is designed exclusively for the purposes described below. Using the fitting for purposes other than those mentioned is considered contrary to its designated use. KIESELMANN GmbH cannot be held liable for any damage resulting from such use. The risk of such misuse lies entirely with the user. The prerequisite for the reliable and safe operation of the fitting is proper transportation and storage as well as competent installation and assembly. Operating the fitting within the limits of its designated use also involves observing the operating, inspection and maintenance instructions.

## 1.4 Personnel

Personnel entrusted with the operation and maintenance of the tank safety system must have the suitable qualification to carry out their tasks. They must be informed about possible dangers and must understand and observe the safety instructions given in the relevant manual. Only allow qualified personnel to make electrical connections.

## **1.5 Modifications, spare parts, accessories**

Unauthorized modifications, additions or conversions which affect the safety of the fitting are not permitted. Safety devices must not be bypassed, removed or made inactive. Only use original spare parts and accessories recommended by the manufacturer.

## **1.6 General instructions**

The user is obliged to operate the fitting only when it is in good working order. In addition to the instructions given in the operating manual, please observe the relevant accident prevention regulations, generally accepted safety regulations, regulations effective in the country of installation, working and safety instructions effective in the user's plant.

## 2 Safety instructions

### 2.1 Intended use

Based upon its functions, the double seat valve is suitable for use in the food and beverages, in pharmaceutical, biotechnological and chemical industries. It is used mainly in combinations with several other double seat valves for the purpose of emptying and filling containers with the possibility of connecting several pipes to one tank.

### 2.2 General notes



#### NOTICE - observe the operating instructions

To avoid danger and damage, the fitting must be used in accordance with the safety instructions and technical data contained in the operating instructions.



#### NOTICE

All data are in line with the current state of development. Subject to change as a result of technical progress.

### 2.3 General safety instructions



#### ⚠ WARNING

##### Risk of injury by moving parts

Do not grab into the valve when the actuator is pressurized. Limbs can be crushing or amputating.

- Remove the control air line before dismantling.
- Ensure that the actuator is unpressurized.



#### ⚠ WARNING

##### Risk of injury by outflowing medium

Dismantling the valve or valve assemblies from the plant can cause injuries.

- Medias flowing through the leakage drain outlet are to be drained off without splashing into a discharge arrangement.
- Carry the disassembling only if when the plant has been rendered pressure-less and free of liquid and gas.



#### ⚠ WARNING

##### Risk of injury by pre-stressed pressure spring.

The actuator is spring-loaded. When disassembling the actuator, components that jump out may cause injuries.

- For dismantling please observe the separate assembly instructions.
- We recommend having the manufacturer do the maintenance work required for the actuation.



#### ⚠ WARNING

##### ATEX - Guidelines

If the valve or the plant is operated in a potentially explosive atmosphere, the valid ATEX directive of the EC and the installation instructions in this operating manual must be observed.

**⚠ CAUTION**

When mounting the clamps, the max. torque must not be exceeded.  
(see technical data)

**⚠ CAUTION**

To avoid air leaking, only use pneumatic connection parts that have an O-ring seal facing the even surface.

**⚠ CAUTION**

Before starting the system, the entire pipeline system must be thoroughly cleaned.

**⚠ CAUTION**

Steps should be taken to ensure that no external forces are exerted on the fitting.

## 3 Delivery, transport and storage

### 3.1 Delivery

- Immediately after receipt check the delivery for completeness and transport damages.
- Remove the packaging from the product.
- Retain packaging material, or expose of according to local regulations.

### 3.2 Transport



#### ⚠ CAUTION

##### **Risk of injury and damage to the product**

During the transport the generally acknowledged rules of technology, the national accident prevention regulations and company internal work and safety regulations must be observed.

### 3.3 Storage



#### NOTICE

##### **Damage to the product due to improper storage!**

Observe storage instructions  
avoid a prolonged storage



#### INFORMATION

##### **Recommendation for longer storage**

We recommend regularly checking the product and the prevailing storage conditions during long storage times.

- To avoid damage to seals and bearings,
  - products up to DN 125 / OD 5 inch should be stored horizontally for maximum 6 months.
  - products larger than DN 125 / 5 inch, should be stored in the upright position with the actuator on top.
- Don't store any objects on the products.
- Protect the products for wetness, dust and dirt.
- The product should be stored in a dry and well ventilated room at a constant temperature (optimal indoor temperature: 25 C ±5 ; indoor humidity data 70% ±5%).
- Protect seals, bearings and plastic parts for UV light and ozone.



## 4 Function and operation

### 4.1 Description of function

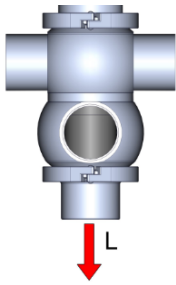

The valve opens from the top down by means of control air and closes bottom to top by means of spring tension without loss of product. In the closed setting, mix-proof separation of the media flowing in the upper and lower valve chambers is ensured by two independently closed valve plates. Any leaks occurring due to damaged valve plate seals are drained to the exterior without pressure via the leakage discharge (L).

### 4.2 Control system and position indicator



#### Feedback unit -optional-

Optionally, modular valve control head systems can be installed to the actuator for reading and actuating valve positions. The standard version is a closed system with SPS or ASI-bus switch-on electronics, and integrated 3/2-way solenoid valves. For tough operating conditions we recommend employing a high-grade steel cover.



#### Feedback unit with finger guard -optional-

For the acquisition of the valve positions over inductive initiators (Sensors), a feedback unit is mounted on the actuation. The enquiry takes place over the position of the piston rod.

### 4.3 Pneumatic valve activation

Valve function	Pneum. activation via control head with solenoid valves (MV)	Pneum. activation via external Solenoid valves (MV external)
main lift valve "OPEN"	control air feed P - MV1 - P1/LA1	control air feed ext.MV1 - LA1
main lift valve "CLOSE"	de-aeration P1/LA1 - MV1 - R valve is closing by spring	de-aeration LA1 - ext.MV1 valve is closing by spring
lifting lower seat	OPEN = control air feed P - MV2 - P2/LA2	OPEN = control air feed ext.MV2 - P - LA2
	CLOSE = de-aeration P2/LA2 - MV2 - R valve is closing by spring	CLOSE = de-aeration LA2 - P - ext.MV2 valve is closing by spring
Lifting upper seat	OPEN = control air feed P - MV3 - P3/LA3	OPEN = control air feed ext.MV3 - LA3
	CLOSE = de-aeration P3/LA3 - MV3 - R valve is closing by spring	CLOSE = de-aeration LA3 - ext.MV3 valve is closing by spring

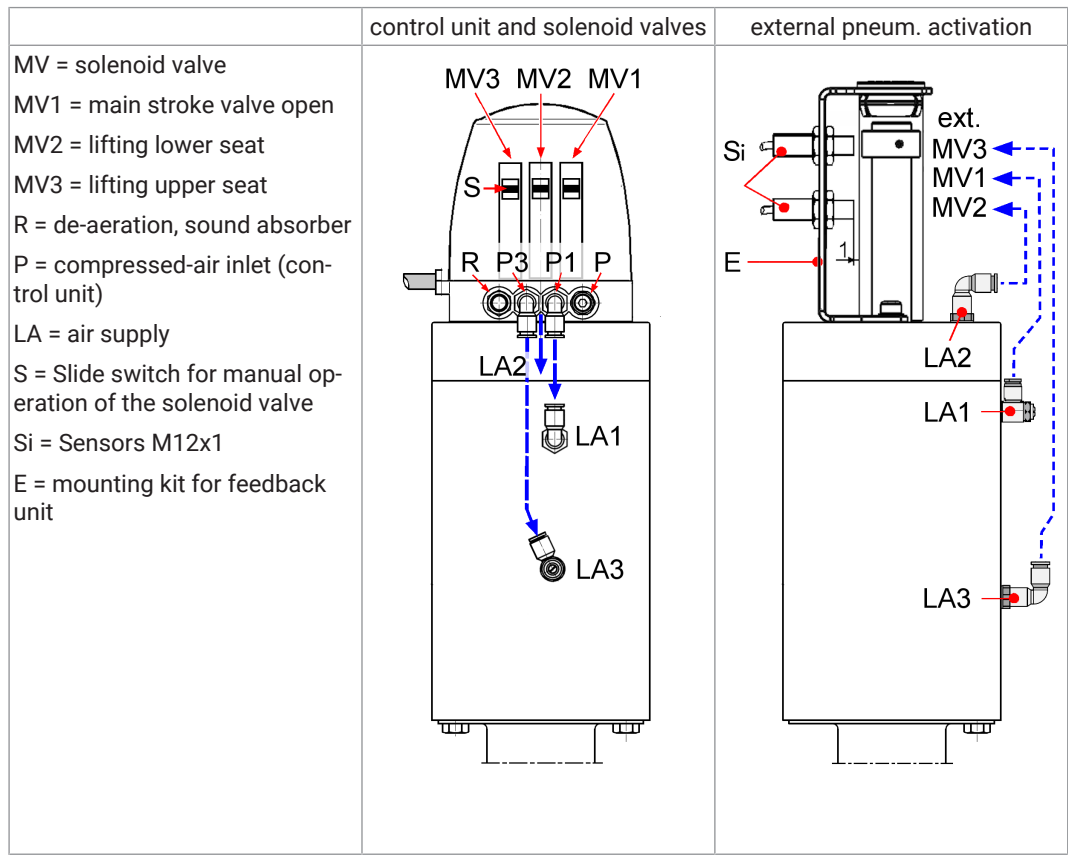

## 5 Commissioning, service and maintenance

### 5.1 Commissioning



#### NOTICE

##### Checking the solenoid valves in the control head

Before using the valve for the first time, the function of the solenoid valves in the control head must be checked.

- Remove the hood on control head.
- Connect the supply air to the control head
- Check the valve functions using the slide switches on the solenoid valve

⇒ Please also read the [documentation for control heads!](#)

#### 5.1.1 Installation instructions

##### Fitting position

The valve must be installed vertically with the actuator at the upwards. Liquid must be able to flow freely from the valve housing.

#### 5.1.2 General welding guidelines

Sealing elements integrated in weld components must generally be removed prior to welding. To prevent damage, welding should be undertaken by certified personnel (EN ISO 9606-1). Use the TIG (Tungsten Inert Gas) welding process.



#### CAUTION

##### Damage and injuries due to high temperature supply

To avoid a distortion of the components, all welding parts must be welded to stress-relieved. Allow all components to cool before assembling.



#### NOTICE

##### Damage due to impurities

Impurities can cause damage to the seals and seals area.  
Clean inside areas prior to assembly.

#### 5.1.3 ATEX - Guidelines

For valves or plants/installations that are operated in the ATEX area, sufficient bonding (grounding) must be ensured (see valid ATEX Guidelines EG).

### 5.2 Service



#### RECOMMENDATION

##### Replacement of seals

To achieve optimal maintenance cycles, the following points must be observed!

- When replacement of seals, all product-contacting seals should be replaced.
- Only original spare parts may be installed.

##### Maintenance interval

The maintenance intervals depend on the operating conditions "temperature, temperature-intervals, medium, cleaning medium, pressure and opening frequency". We recommend replacing the seals 1-year cycle. The user, however should establish appropriate maintenance intervals according to the condition of the seals.

**Lubricant recommendation**

	EPDM; HNBR; NBR; FKM; k-flex	- Klüber Paraliq GTE703*
	Silicone	- Klüber Sintheso pro AA2*
	Thread	- Interflon Food*
*) It is only permitted to use approved lubricants, if the respective fitting is used for the production of food or drink. Please observe the relevant safety data sheets of the manufacturers of lubricants.		

**Maintenance - Lift actuator**

The actuator is maintenance-free and non-removable.

**5.2.1 Maintenance table**

		Annually	Additional information
5.2	Service	1	

1 - Maintenance personnel

**5.3 Cleaning**

**Cleaning**

Cleaning of the housing is performed with the pipe cleaning system. As part of the cleaning program, the leakage chamber and the drain pipe can be cleaned by cycling the valve discs. The valve disc shaft is also cleaned when the upper valve disc is cycled.

Alternatively, the leakage chamber and the shaft of the upper valve disc can be cleaned by means of the external rinsing connection (Sp). For cleaning the shaft, the upper valve disc has to be lifted.

## 6 Technical data

### 6.1 Double seat valve Type 567x

<b>Model:</b>	Double seat valve	
<b>Valve size:</b>	DIN: DN25 - DN150 Inch: OD1 - OD4	
<b>Connections:</b>	Weld-on end DIN EN 10357	
<b>Temperature range:</b>	Ambient temperature:	+4° to +45°C
	Product temperature:	+0° to +95°C (medium dependent)
	Sterilization temperature:	EPDM +140°C (SIP 30 min) HNBR +120°C (SIP 30 min)
<b>Operating pressures:</b>	DIN: DN25 - 100 = max. 10 bar DN125 - 150 = max. 6 bar Inch: OD1 - OD4 = max. 10 bar	
<b>Pressure resistance:</b>	40 bar	
<b>Leak rate:</b>	A (DIN EN 12266-1)	
<b>Control air:</b>	<u>Control air pressure:</u> 5,5 - 8,0 bar	<u>Quality of control air:</u> ISO 8573-1 : 2001 quality class 3
<b>Materials:</b> (in product contact)	Stainless steel:	1.4404 / AISI316L
	Surfaces:	Ra < 0,8µm e-polished
	Sealing material:	EPDM (FDA) HNBR (FDA)

### 6.2 KV - value

	DN	25	40	50	65	80	100	125	150
	Inch	1	1½	2	2½	3	4	5	6
flow direction:		[m³/h]							
transition-flow at top ↔		26	50	95	150	240	380	580	940
transition-flow at bottom ↔		26	55	100	155	250	390	590	940
from bottom to top ↑		16	26	45	72	98	155	245	370
from top to bottom ↓		16	24	43	67	93	150	240	330

### 6.3 Cleaning flow rate

Cleaning parameters for the leakage chamber			Nominal diameter DN / OD							
Cleaning step	valve disc lifting	DIN Inch	25 1	40 1½	50 2	65 2½	80 3	100 4	125 -	150 -
Pre-Rinse	-	lifting upper seat	0.97	1.10	1.1	1.38	1.66	2.08	2.50	4.02
Wash 80°C	3 x 5 sec.									
Intermediate rinse	2 x 5 sec.		(l/s at 3bar)							
Acid	3 x 5 sec.	lifting lower seat	0.54	0.69	0.69	0.83	0.83	1.25	1.66	2.50
Final rinse	2 x 5 sec.									

## 6.4 Torques

	DN	25	40	50	65	80	100	125	150
	Inch	1	1½	2	2½	3	4	5	6
<b>Clamp coupling (Nm):</b>		15	15	15	25	25	55	65	65

## 7 Disassembly and assembly

### 7.1 Disassembly



#### NOTICE

All threaded joint have right-hand thread.

Unscrew and remove control air, steam resp. cleaning lines and electrical lines, complete feedback unit or control head.

#### Mounting tools

Mounting tools sets:			DN40 - DN65	5670 065 100-000			
			DN80 - DN100	5670 100 100-000			
			DN125 - DN150	5670 150 100-000			
M1		Socket	DN40 - DN65	5620 065 131-130			
			DN80 - DN150	5620 100 131-130			
M2		Eccentric socket	DN40 - DN65	5620 065 134-130			
			DN80 - DN150	5620 100 134-130			
M3		Centring ring	DN40/50	5620 050 025-020			
			DN65	5620 065 025-020			
			DN80	5620 080 025-020			
			DN100	5620 100 025-020			
			DN125	5620 125 025-020			
			DN150	5620 150 025-020			
M4		Joint -pin wrench	DN40 - DN65	5620 065 015-000			
			DN80 - DN150	5620 150 015-000			
M5		Socket + guide bush (POM) + O-rings	DN40 - DN65	5670 080 105-000			
			DN80 - DN100	5670 100 105-000			
			DN125 - DN150	5670 150 105-000			
M6		Mounting plate	DN40 - DN65	5620 065 121-020			
			DN80 - DN100	5620 100 121-020			
			DN125 - DN150	5620 150 121-020			
ST1 6		Mounting wrench	DN40 - DN150	5670 150 126-020			

### 7.1.1 Assembly valve insert VE

- Unscrew the upper retaining clamp (VK).
- Connect compressed air to LA1 and pressurize the actuator with air.
  - The valve insert lift up of the valve housing (VG).
- Pinch a rubber (T) between the Lantern (15) and the housing (VG).
- Disconnect compressed air at LA1 and depressurize the drive - The valve piston move in. - The valve piston move in.
- Remove the complete valve insert with the upper shaft seal (D1) from the housing (VG).
- Unscrew the lower retaining clamp (VK).
- Remove the housing bottom (1) with the lower shaft seal (D1) from the housing (VG).

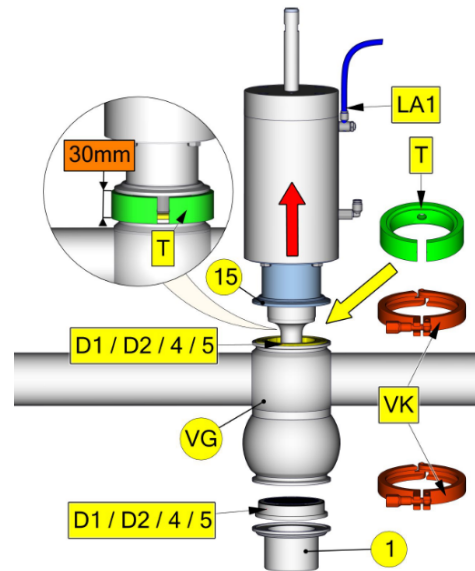

### 7.1.2 Replacement wear parts

#### Disassembly

- Unscrew nut (11) and remove disc (10).
- Dismount the upper piston (6) from the upper piston (7) in direction X.
- Remove the split washer (13).

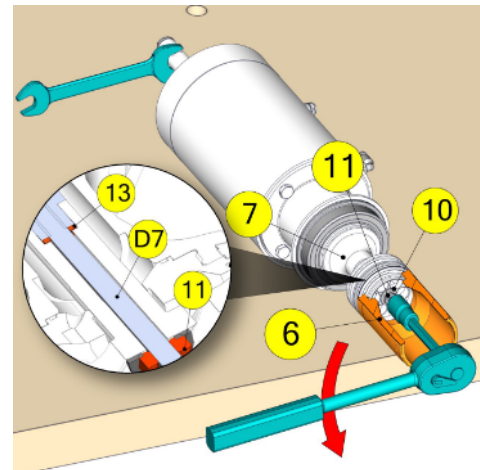

- Remove O-ring (D5).
- Unscrew the hexagon screws (14).
- Push the lantern (15) in direction 'X' until the hole (B1) is freely visible.

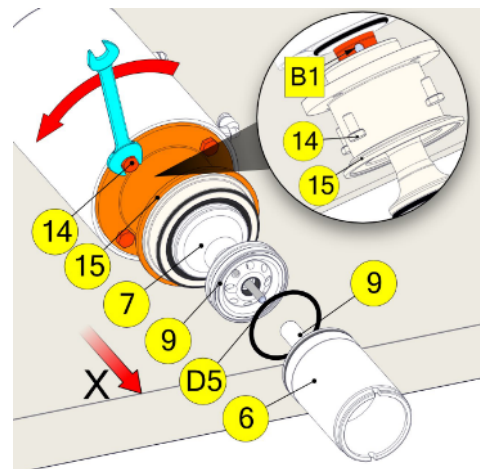



- Unscrew the upper piston (7) from piston rod (3). Use the mounting plate M6.  
Counter with the pin wrench M4 at the hole (B1).

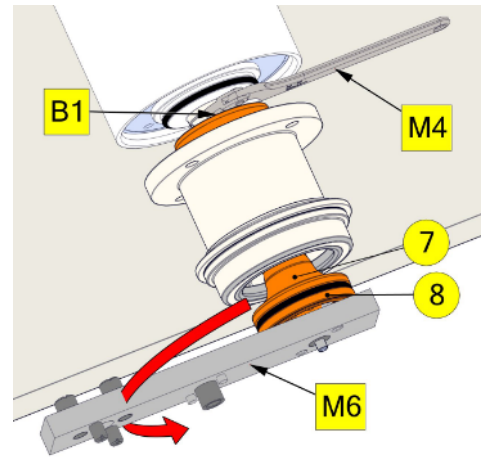

- $\geq 40 / 1\frac{1}{2}$  (valves with divided pistons):  
Should be untighten the piston plate (8) before piston (7), then unscrew the piston (7) with the eccentric M2 and a ratchet.

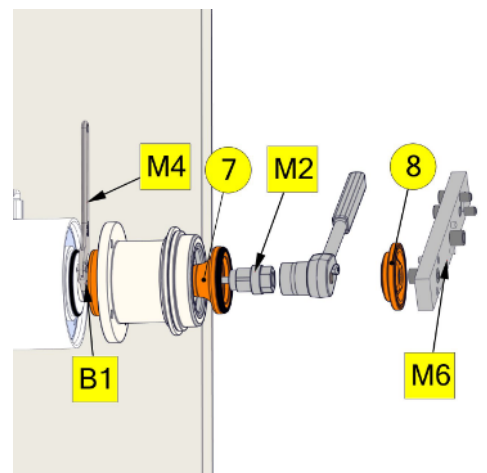

- Push the lantern (15) and the upper shaft seal (D1) from the piston (7).
- Dismount the valve lift stop (16).
- Remove seals: Pos. (D1); (D2); (D8); (D9); (D10).

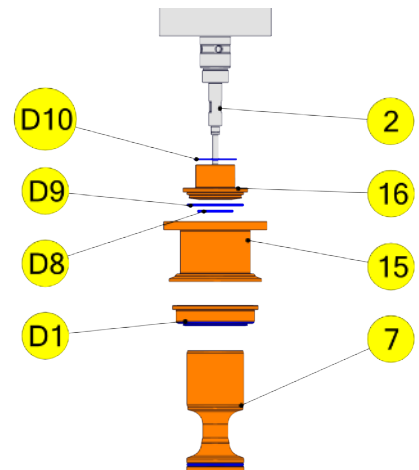

### 7.1.2.1 Assembly seal (D4)

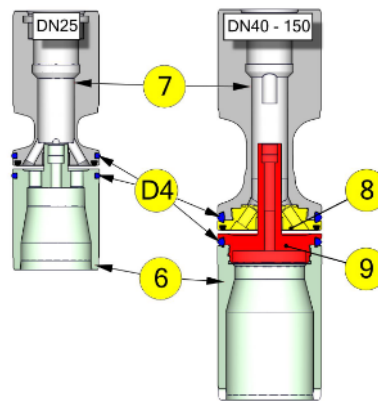

Model Seal (D4)	Piston (6) and (7)		Pair of piston upper (7) and (8) Pair of piston lower (6) and (9)	
	DN 25	DN 40 - 125	DN 150	
	OD 1"	OD 1½" - 5"	OD 6"	
	Piston <u>undivided</u> <u>divided</u> <sup>1</sup>	Piston divided	Piston divided	
O-ring	x	x	x	
Seal (with Support ring)	-	x	-	

<sup>1</sup>)According their construction from valve size DN 25/1", the pistons (6) and (7) are not divided.

#### DN25 Dismount (D4) (O-ring version, Piston not divided)

- Puncture the O-ring (D4) with a needle and remove them from the groove of piston (6) and (7).

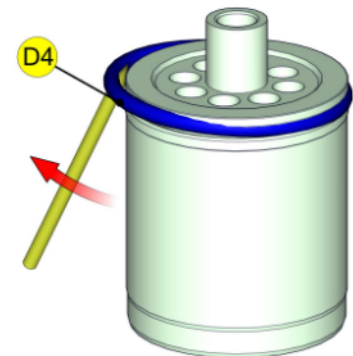

#### DN40 - DN150 Dismount O-ring / seal (D4)

- Clamp the mounting plate M6 into the vice.
- Put the piston (6) resp. (7) in the fittingly pins. (see Fig. 5 - 8).
- Unscrew the piston (6) from piston plate (9) with the socket M5 and the mating reducing bush.
- Unscrew the piston (7) from piston plate (8) with the socket M1.

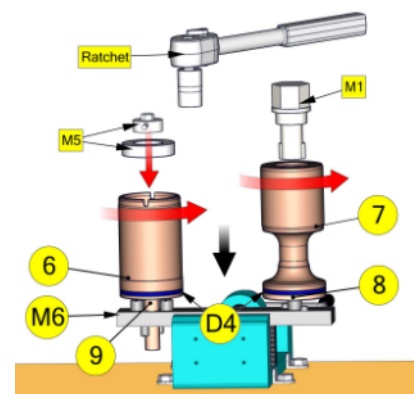

- Remove seals resp. O-rings (D4).

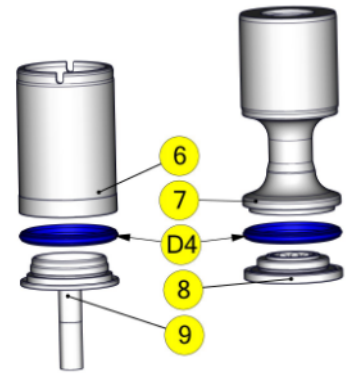

## 7.2 Assembly

Assemble in reverse order.

Thoroughly clean and slightly lubricate mounting areas and running surfaces.



### NOTICE

**During assembly, the following points must be observed!**

Folgen

- Always replace the hexagon lock nut (11) by a new one after unscrewing.
- Carefully fit in the complete valve insert into the casing. When fitting the valve insert and running surfaces onto the piston, do not damage.
- - Check valve functions by manually activating the 3/2-way solenoid valves after assembly!

#### Mounting clamp coupling (VK)

- For mounting the clamp coupling (VK), please note that it continuously fits form locking to the inclinations of the casing and the lantern/casing bottom.
- The centring of the retaining clamp (VK) during tightening can be accomplished with a slight beat (please use a soft-head hammer) on the extent of the retaining clamp (VK).
- Beim Anziehen der Verschlussklammer (VK) muss das Drehmoment und die Spaltgröße 'S' (When tightening the clamp coupling (VK), please pay attention to the turning moment and the gap size 'S' ( $\leq 0,4\text{mm}$ ) between casing and lantern/casing bottom.

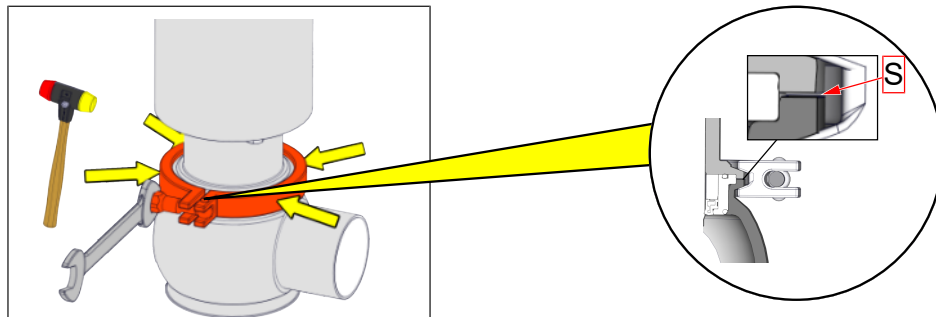

	DN	25	40	50	65	80	100	125	150
	Inch	1	1½	2	2½	3	4	5	6
<b>Clamp coupling (Nm):</b>		15	15	15	25	25	55	65	65

### Mounting seal (D4) for divided piston

Pair of piston lower = Piston (6) and piston plate (9)

Pair of piston upper = Piston (7) and piston plate (8)

- Screw together the pair of piston (7) / (8) and (6) / (9) without the seal (D4) to the metal limit stop by hand.
- Make a colored mark at the piston surfaces.
- After then, unscrew the pairs of piston again.

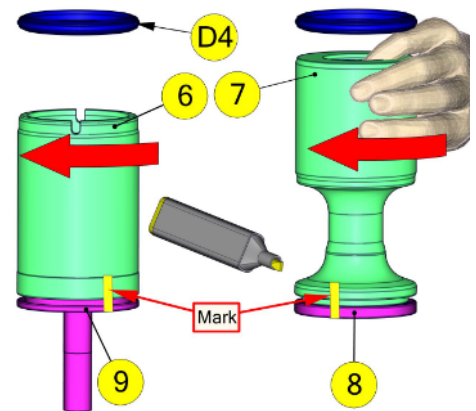

- Slide the seal (D4) onto the pistons.
- Screw together the pair of piston by hand again.
- Clamp the mounting plate M6 into the vice.
- Fix the lower pair of piston (6) / (9) with the piston plate (9) in the mounting plate.
- Position the eccentric ring (M3) on seal (D4).
- Screw up the piston (6) to the final limit mark. Use the socket M5 and a ratchet.

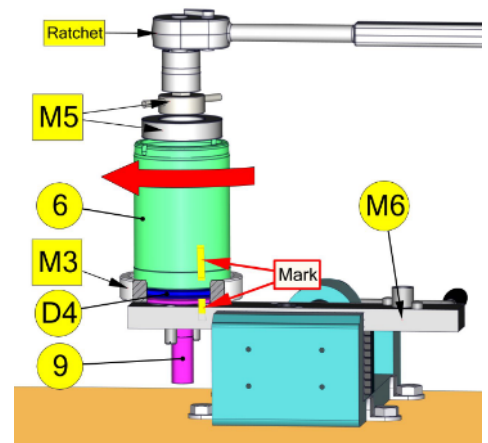

- Clamp the socket M1 into the vice at the hexagon flat. Fix the upper pair of piston (7) / (8) with the piston (7) of the socket M1.
- Fix the upper pair of piston (7) / (8) with the piston (7) of the socket M1.
- Position the eccentric ring (M3) on seal (D4).
- Screw up the piston plate (8) to the final limit mark. Use the mounting plate M6.

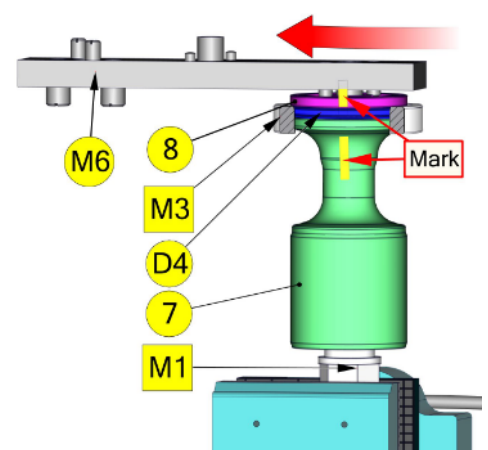

**Mounting O-ring (D4) for undivided piston**

- Slide the O-ring onto the groove.  
Resolve contingently twisting of the seal with a rod between seal and groove.  
OAlternately press and roll the seal into the groove with round body.

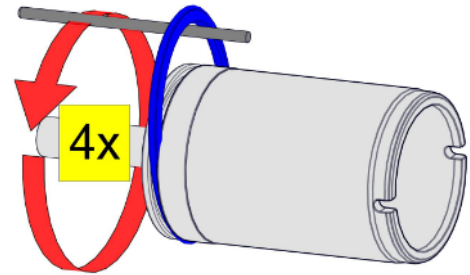

7.2.1 Seals (D4)

Seal D4 - Elastomer

Model Seal (D4)	Piston (6) and (7)	Pair of piston upper (7) and (8) Pair of piston lower (6) and (9)	
	DN 25 OD 1"	DN 40 - 125 OD 1½" - 5"	DN 150 OD 6"
	Piston <u>not divided</u> <sup>1</sup>	Piston <u>divided</u>	Piston <u>divided</u>
O-ring EPDM	x	x <sup>2</sup>	x
O-ring HNBR	x	x <sup>3</sup>	x
Seal EPDM (with Support ring)	-	x	-
Seal HNBR (with Support ring)	-	x	-

1. According their construction from valve size DN 25/1", the pistons (6) and (7) are not divided.
2. O-ring version till 05/2016 thereafter seal EPDM (D4)c
3. O-ring version till 05/2016 thereafter seal (D4)d

Seal - Model	
D4 = Seal D4-1 = Seal jacket (seal material) D4-2 = Backup ring	
D4 = O-ring	

## 7.2.2 Shaft sealing

### Shaft sealing - Elastomer

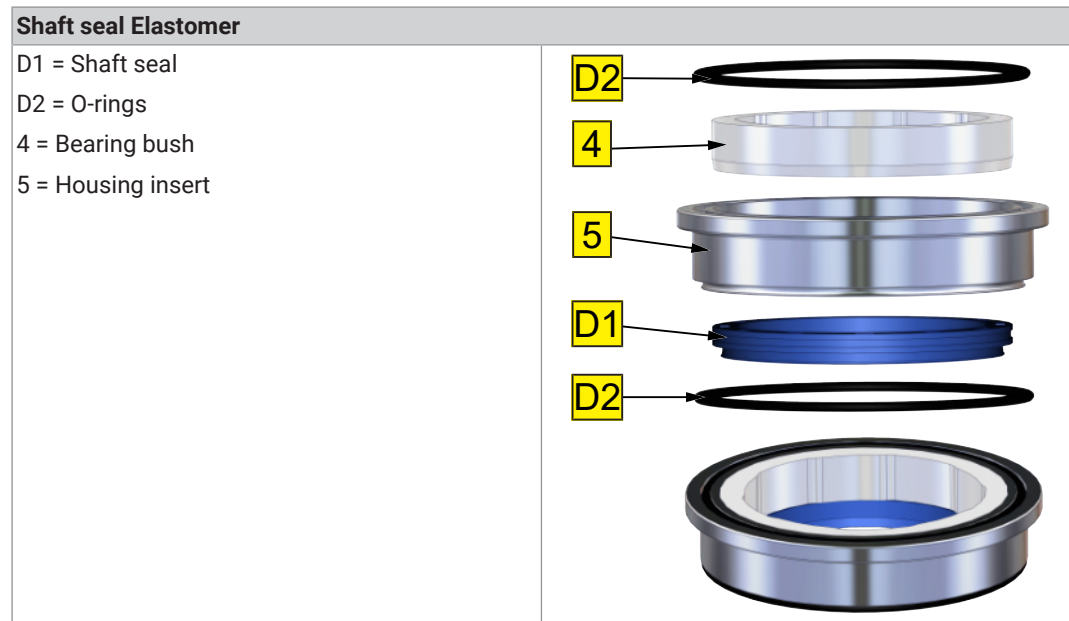



## 8 Drawings and dimensions

### 8.1 Double seat valve

- A = Control head
- E = Feedback unit
- IG = Pulse generator
- K = Cap
- VE = Valve insert
- VG = Valve housing
  - S-S
  - SS-S
  - S-SS
  - SS-SS

- VK = Clamp coupling
- 1a = Housing bottom
- 1b = Housing bottom with rinsing connection
- 4 = Bearing bush
- 5 = Housing insert
- 14 = Screws
- 15a = Lantern
- 15b = Lantern with rinsing connection
- Sp1 = Screwed socket with cutting ring union
- Sp2 = Screwed socket DN15

- D1 = Shaft seal
- D2 = O-rings
- D11 = O-ring
- D12 = Seal
- D13 = O-ring

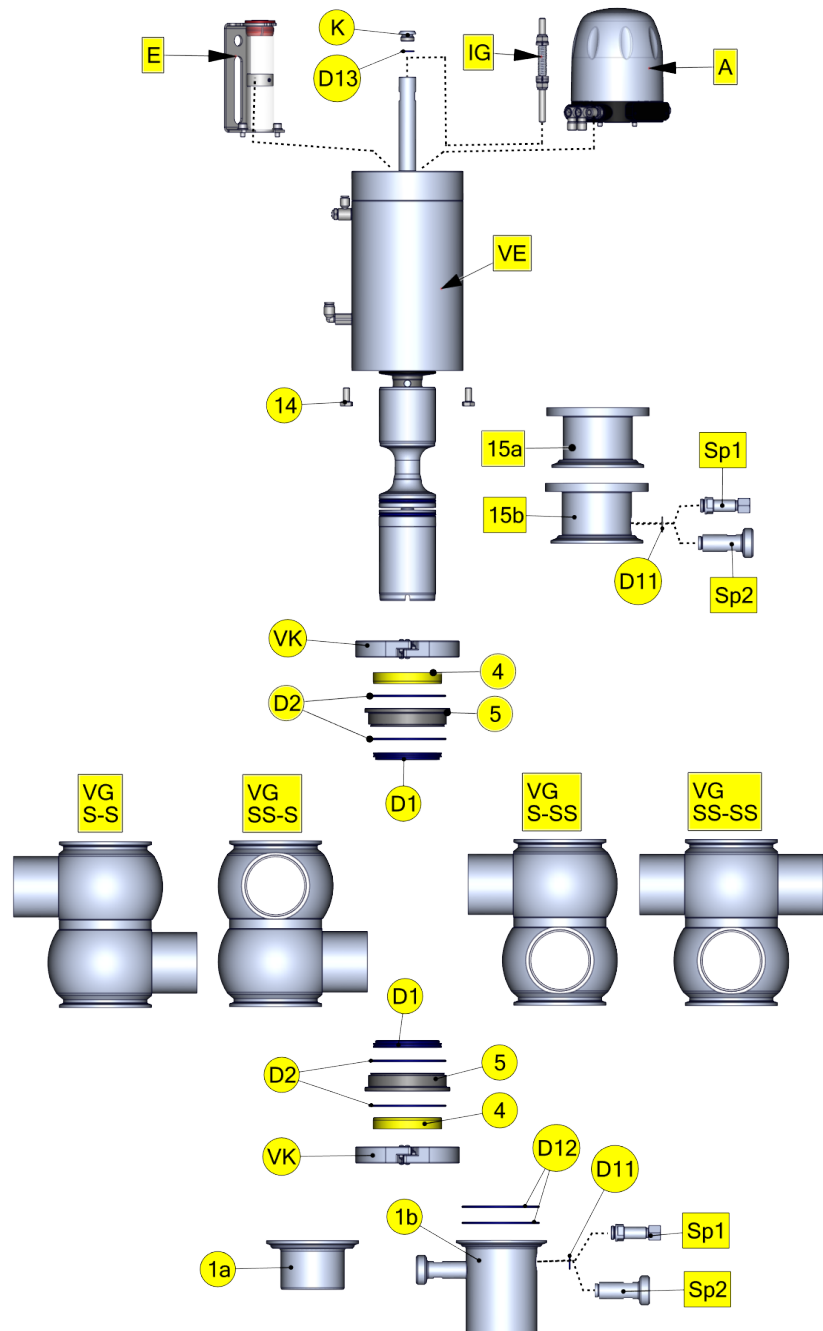

**Valve insert VE DN25 / 1 Inch**

- 1 = -
- 2 = Spindle
- 3 = Piston rod
- 4 = Bearing bush
- 5 = Housing insert
- 6 = Piston lower
- 7 = Piston upper
- 8 = -
- 9 = -
- 10 = Disc
- 11 = Hexagon nut
- 12 = Plain bearing
- 13 = Split washer
- 14 = Hexagon screws
- 15 = Lantern
- 16 = Valve lift stop
- 17 = pneum. Pneum. actuator

Seal kit

- D1 = Shaft seal
- D2 = O-ring
- D3 = -
- D4 = O-ring
- D5 = O-ring
- D6 = -
- D7 = Headless pin
- D8 = O-ring
- D9 = O-ring
- D10 = O-ring

- B = Mounting bore
- E = Nut
- L = Leakage drain
- G1 = Lock nut high strength (e.g. Loctite 2701)
- LA1 = Main lift
- LA2 = lifting lower seat
- LA3 = lifting upper seat
- Y = Detail

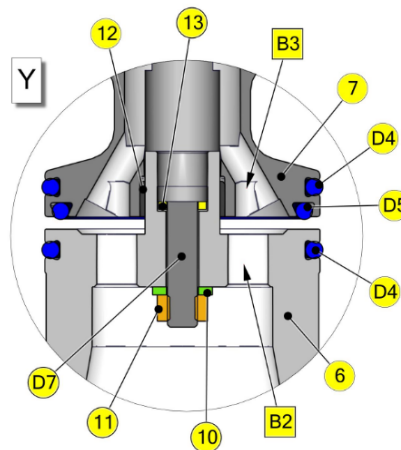
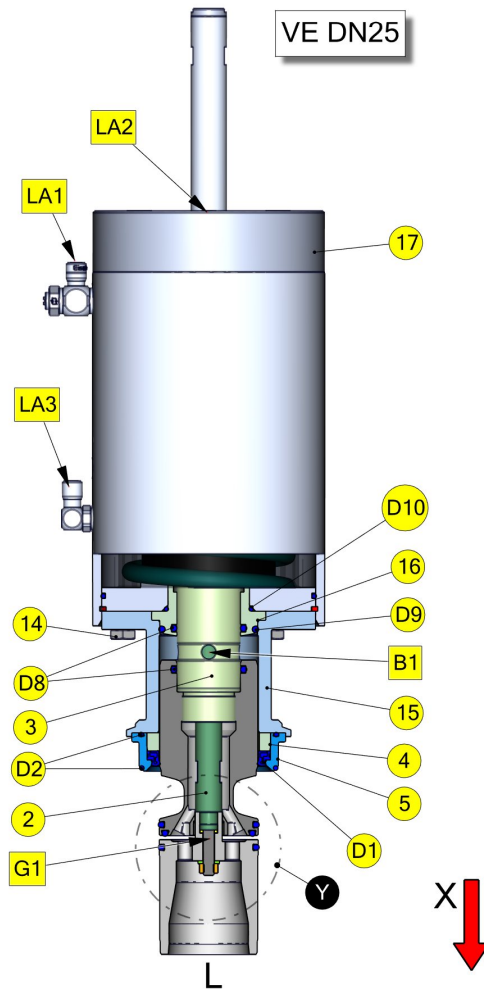

**VE = Valve insert VE DN40 - 150 / 1½ - 4 Inch**

- 1 = -
- 2 = Spindle
- 3 = Piston rod
- 4 = Bearing bush
- 5 = Housing insert
- 6 = Piston lower
- 7 = Piston upper
- 8 = Piston plate upper
- 9 = Piston plate lower
- 10 = Disc
- 11 = Hexagon nut
- 12 = Plain bearing
- 13 = Split washer
- 14 = Hexagon screws
- 15 = Lantern
- 16 = Valve lift stop
- 17 = pneum. Pneum. actuator

Seal kit

- D1 = Shaft seal
- D2 = O-ring
- D3 = O-ring
- D4 = Seal
- D5 = O-ring
- D6 = O-ring
- D7 = Headless pin
- D8 = O-ring
- D9 = O-ring
- D10 = O-ring

- B = Mounting bore
- E = Nut
- L = Leakage drain
- G1 = Lock nut high strength (e.g. Loctite 2701)
- LA1 = Main lift
- LA2 = lifting lower seat
- LA3 = lifting upper seat
- Y = Detail

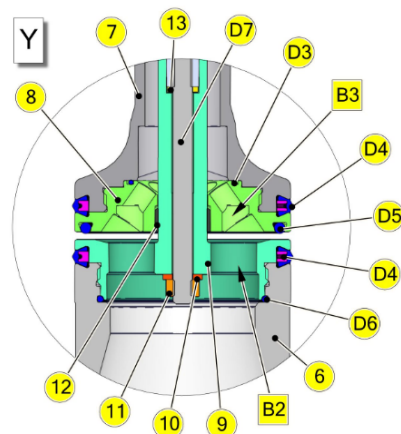
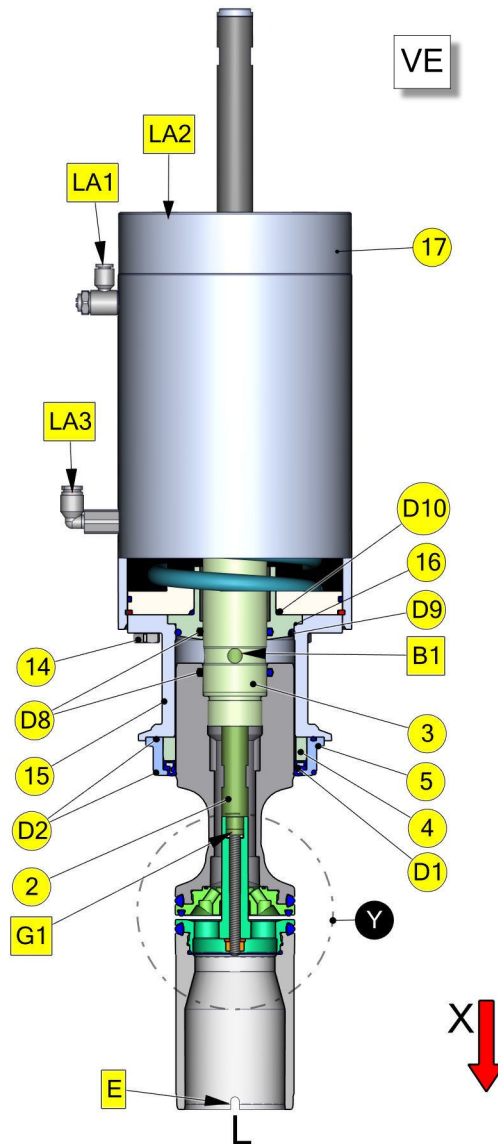

## 8.1.1 Dimensions

	DIN	25	40	50	65	80	100	125	150
	Inch	1	1½	2	2½	3	4	5	6
D1 / D2	DIN	Ø29x1,5	Ø41x1,5	Ø53x1,5	Ø70x2	Ø85x2	Ø104x2	Ø129x2	Ø154x2
	Inch	Ø25.4x1.65	Ø38,1x1,65	Ø50,8x1,65	Ø63,5x1,65	Ø76,1x2	Ø101,6x2	-	Ø152-4x2,77
D3	DIN	Ø 128	Ø 128	Ø 128	Ø 128	Ø 160	Ø 160	Ø 230	Ø 230
	Inch	Ø 128	Ø 128	Ø 128	Ø 128	Ø 160	Ø 160	-	Ø 230
Sp1	DIN	- rinsing connection with cutting ring union M14x1,5 for tube Ø8x1							
Sp2	Inch	- Standard rinsing connection screwed socket DN15DIN 11851							
L1	DIN	150	170	170	210	230	260	320	345
	Inch	150	170	170	240	230	260	-	345
L2	DIN	112	132	155	193	228	269	315	351
	Inch	112	127.5	152	189	220	260	-	343
L3	DIN	46	59	71	87	106	125	150	175
	Inch	42	56	69	81	98	122	-	172
L4	DIN	448	447	446	464	531	560	615	628
	Inch	448	447	446	464	531	560	-	634
L5	DIN	-	-	-	172	192.5	232	-	-
	Inch	-	-	-	-	-	-	-	-
<b>Size when completed</b>									
M1 Valve + Control head	DIN	580	600	625	680	785	850	960	1015
	Inch	580	600	625	680	785	850	-	1015
M2 Valve + Control head + Rinsing connection lower	DIN	-	-	-	955	1080	1185	-	-
	Inch	-	-	-	-	-	-	-	-

Table 1 Measurement schedule

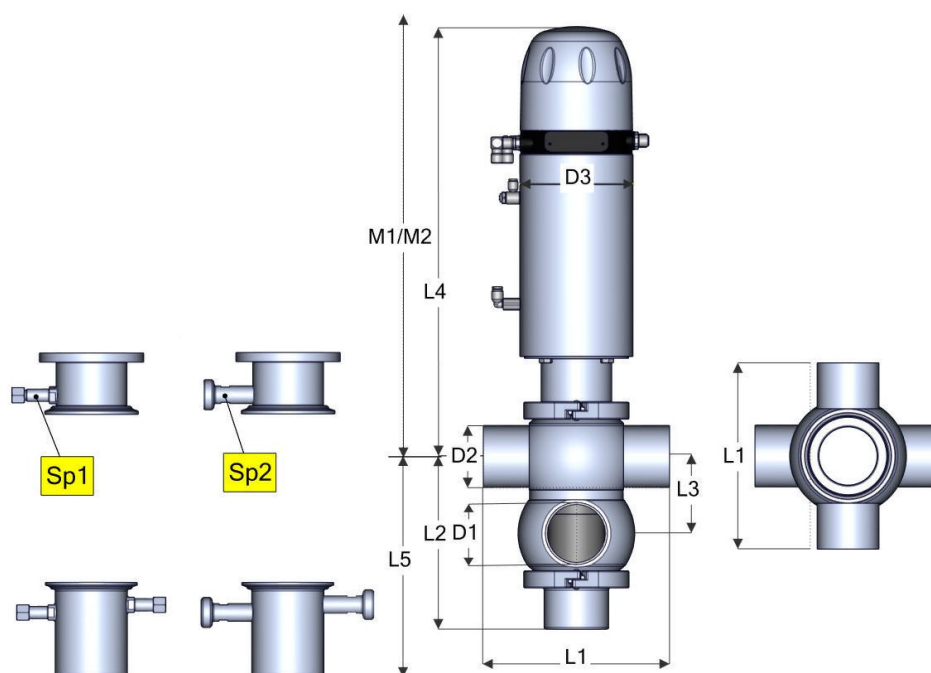
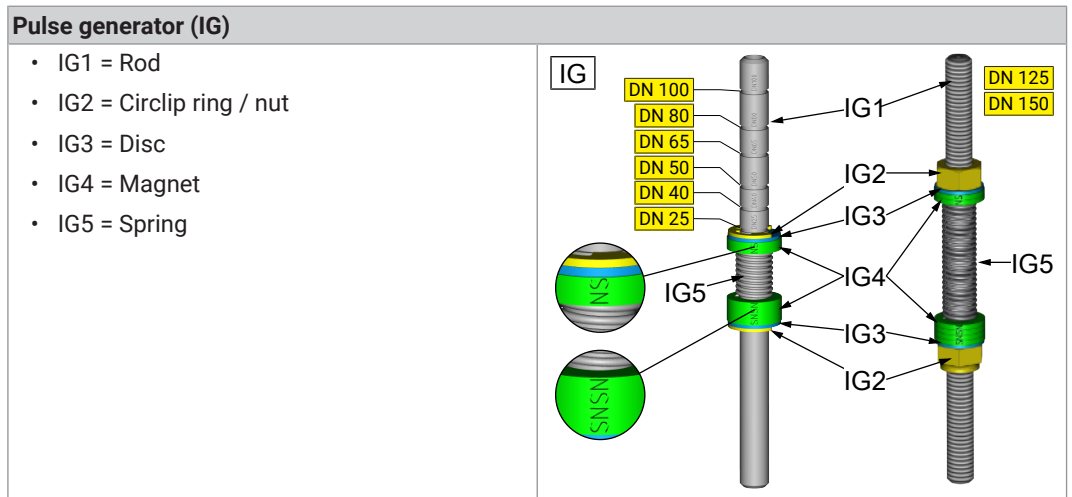
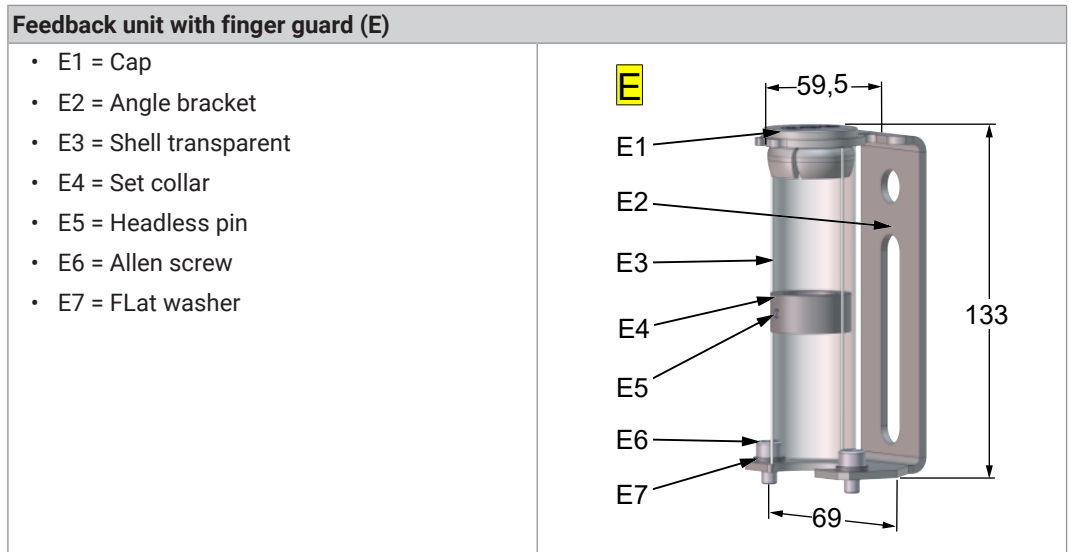
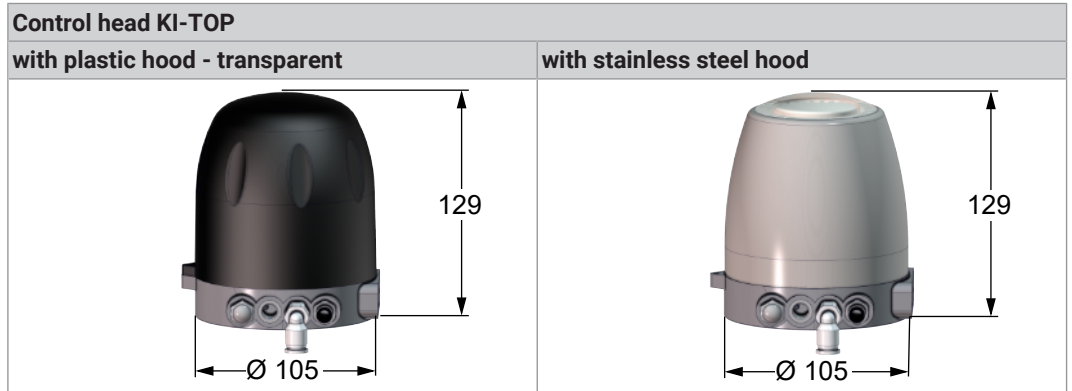

Illustration 1

## 8.2 Control units



## 9 Wearing parts

### 9.1 Double seat valve Type 567x DN25 / OD 1 Inch

#### Valve inserts and Wear part kits

Housing variation	Seal	Item number	Valve insert VE	Wear parts kit	
Standard					
	SS - S	EPDM	5671 DN 130 - xxx	5670 DN 030-041	5670 025 130-000
	S - S		5672 DN 130 - xxx		
	S - SS		5673 DN 130 - xxx		
	SS - SS		5674 DN 130 - xxx		
	SS - S	HNBR	5671 DN 420 - xxx	5670 DN 050-041	5670 025 420-000
	S - S		5672 DN 420 - xxx		
	S - SS		5673 DN 420 - xxx		
	SS - SS		5674 DN 420 - xxx		
ext. rinsing connection upper					
	SS - S	EPDM	5671 DN 760 - xxx	5670 DN 760-041	5670 025 769-000
	S - S		5672 DN 760 - xxx		
	S - SS		5673 DN 760 - xxx		
	SS - SS		5674 DN 760 - xxx		
	SS - S	HNBR	5671 DN 770 - xxx	5670 DN 770-041	5670 025 779-000
	S - S		5672 DN 770 - xxx		
	S - SS		5673 DN 770 - xxx		
	SS - SS		5674 DN 770 - xxx		
Rinsing connection upper with cutting ring union M14x1,5 for tube Ø8x1					
	SS - S	EPDM	5671 DN 762 - xxx	5670 DN 762-041	5670 025 769-000
	S - S		5672 DN 762 - xxx		
	S - SS		5673 DN 762 - xxx		
	SS - SS		5674 DN 762 - xxx		
	SS - S	HNBR	5671 DN 772 - xxx	5670 DN 772-041	5670 025 779-000
	S - S		5672 DN 772 - xxx		
	S - SS		5673 DN 772 - xxx		
	SS - SS		5674 DN 772 - xxx		

DN = Nominal diameter e.g. 5673 025 130-041 = DN 25, 5673 026 130-041 = 1 Inch,  
 xxx = Material in product contact / Exterior finish / Control system (see Classification [▶ 39]),  
 S = Welded end

**Spare parts lists**

Double seat valve DN 25 / OD 1 Inch

Pos	Designation	Material	DN 25	OD 1 Inch
1a	Housing bottom	AISI303	5671 025 011-220	5671 026 011-220
1b	Housing bottom with rinsing connection	AISI303	-	-
2	Spindle	AISI303	5622 065 040-220	5622 065 040-220
3	Piston rod	AISI303	5622 065 041-220	5622 065 041-220
4	Bearing bush (2x)	PTFE	5622 050 006-053	5622 050 006-053
5	Housing insert (2x)	AISI316L	5672 025 004-040	5672 025 004-040
6	Piston lower	AISI316L	5671 025 005-040	5671 025 005-040
7	Piston upper	AISI316L	5622 025 003-040	5622 025 003-040
8	-	-	-	-
9	-	-	-	-
10	Disc	AISI304	8071 064 001-020	8071 064 001-020
11	Hexagon nut	AISI304	8113 006 000-020	8113 006 000-020
12	Plain bearing	XMS	8050 015 007-156	8050 015 007-156
13	Split washer	AISI304	8140 006 001-020	8140 006 001-020
14	Hexagon screw	AISI304	8106 008 016-020	8106 008 016-020
15	Lantern valve insert (a)	AISI304	5624 040 008-021	5624 040 008-021
	Lantern kompl.	AISI304	5624 040 515-021	5624 040 515-021
	- valve insert (b)	AISI304	5624 040 517-021	5624 040 517-021
16	Valve lift stop	AISI303	5622 025 009-220	5622 025 009-220
17	Pneum. Pneum. actuator	AISI304	5620 065 000-021	5620 065 000-021
D13	O-ring	NBR	2304 012 020-055	2304 012 020-055
K	Cap	AISI303	5622 100 071-220	5622 100 071-220
LA1	One-way restrictor	-	8218 001 020-015	8218 001 020-015
LA3	Rapid action hose coupling	-	8217 000 004-015	8217 000 004-015
Sp1	Screwed socket: Rinsing connection M14x1,5 cutting ring union		5624 065 506-220	5624 065 506-220
Sp2	Screwed socket - Rinsing connection DN15	AISI303	5624 065 514-020	5624 065 514-020
VG	Housing SS - S	AISI316L	5621 025 001-041	5661 026 001-041
	S - S		5622 025 001-041	5662 026 001-041
	S - SS		5623 025 001-041	5663 026 001-041
	SS - SS		5624 025 001-041	5664 026 001-041
VK	Clamp coupling (2x)	AISI304	2122 065 100-020	2122 065 100-020

**Wear parts set EPDM**

Double seat valve OD 25 / 1 Inch

Pos.	Designation	Material	DN 25 / OD 1 Inch
	Wear parts set EPDM (A)	EPDM	5670 025 130-000
	Wear parts set EPDM (B) - rinsing connection upper	EPDM	5670 025 769-000
D1	Shaft seal (2x)	EPDM	5622 050 010-069
D2	O-ring (4x)	EPDM	2304 069 026-159
D3	-	-	-
D4	O-ring (2x)	EPDM	2304 047 035-159
D5	O-ring	EPDM	2304 041 035-159
D6	-	-	-
D7	Headless pin	AISI304	8112 006 040-020
D8	O-ring (2x)	EPDM	2304 036 035-159
D9	O-ring	EPDM	2304 047 035-159
D10	O-ring	HNBR	2304 042 025-055
D11	O-ring (Seal kit B)	EPDM	2304 014 020-170
11	Hexagon nut	AISI304	8113 006 000-020

**Wear parts set HNBR**

Double seat valve OD 25 / 1 Inch

Pos.	Designation	Material	DN 25 / OD 1 Inch
	Wear parts set HNBR (A)	HNBR	5670 025 420-000
	Wear parts set HNBR (B) - rinsing connection upper	HNBR	5670 025 779-000
D1	Shaft seal (2x)	HNBR	5622 050 010-050
D2	O-ring (4x)	HNBR	2304 069 026-050
D3	-	-	-
D4	O-ring (2x)	HNBR	2304 047 035-157
D5	O-ring	HNBR	2304 041 035-157
D6	-	-	-
D7	Headless pin	AISI304	8112 006 040-020
D8	O-ring (2x)	EPDM	2304 036 035-159
D9	O-ring	EPDM	2304 047 035-159
D10	O-ring	NBR	2304 042 025-055
D11	O-ring (Seal kit B)	EPDM	2304 014 020-170
11	Hexagon nut	AISI304	8113 006 000-020



## 9.2 Double seat valve Type 567x DN40 - DN150 / 1,5" - 4"

### Valve inserts and Wear part kits

Housing variation	Seal	Item number	Valve insert VE	Wear parts kit	
Standard					
SS - S	EPDM	5671 DN 730-xxx	5670 DN 730-041	a) 5670 DN 739-020 b) 5670 DN 739-000	= with support ring for (D4) = without support ring for (D4)
S - S		5672 DN 730-xxx			
S - SS		5673 DN 730-xxx			
SS - SS		5674 DN 730-xxx			
SS - S	HNBR	5671 DN 720-xxx	5670 DN 720-041	a) 5670 DN 729-020 b) 5670 DN 729-000	= with support ring for (D4) = without support ring for (D4)
S - S		5672 DN 720-xxx			
S - SS		5673 DN 720-xxx			
SS - SS		5674 DN 720-xxx			
ext. rinsing connection upper					
SS - S	EPDM	5671 DN 760-xxx	5670 DN 760-041	a) 5670 DN 769-020 b) 5670 DN 769-000	= with support ring for (D4) = without support ring for (D4)
S - S		5672 DN 760-xxx			
S - SS		5673 DN 760-xxx			
SS - SS		5674 DN 760-xxx			
SS - S	HNBR	5671 DN 770-xxx	5670 DN 770-041	a) 5670 DN 779-020 b) 5670 DN 779-000	= with support ring for (D4) = without support ring for (D4)
S - S		5672 DN 770-xxx			
S - SS		5673 DN 770-xxx			
SS - SS		5674 DN 770-xxx			
Rinsing connection with cutting ring union M14x1,5 for tube Ø8x1					
SS - S	EPDM	5671 DN 762-xxx	5670 DN 762-041	a) 5670 DN 769-020 b) 5670 DN 769-000	= with support ring for (D4) = without support ring for (D4)
S - S		5672 DN 762-xxx			
S - SS		5673 DN 762-xxx			
SS - SS		5674 DN 762-xxx			
SS - S	HNBR	5671 DN 772-xxx	5670 DN 772-041	a) 5670 DN 779-020 b) 5670 DN 779-000	= with support ring for (D4) = without support ring for (D4)
S - S		5672 DN 772-xxx			
S - SS		5673 DN 772-xxx			
SS - SS		5674 DN 772-xxx			
ext. rinsing connection lower					
SS - S	EPDM	5671 DN 793-xxx	5670 DN 793-041	a) 5670 DN 799-020 b) 5670 DN 799-000	= with support ring for (D4) = without support ring for (D4)
S - S		5672 DN 793-xxx			
S - SS		5673 DN 793-xxx			
SS - SS		5674 DN 793-xxx			
SS - S	HNBR	5671 DN 792-xxx	5670 DN 792-041	a) 5670 DN 798-020 b) 5670 DN 798-000	= with support ring for (D4) = without support ring for (D4)
S - S		5672 DN 792-xxx			
S - SS		5673 DN 792-xxx			
SS - SS		5674 DN 792-xxx			

DN / OD = Nominal diameter e.g. 5673 050 130-041 = DN50 , 5673 051 130-041 = 2Inch

xxx = Material in product contact / Exterior finish / Control system (Classification [► 39])

S = Welded end

**Spare parts list**

Double seat valve DN 40 - 80 / 1½ - 3 Inch

Pos	Designation	Material	DN 40 / 1½ Inch	DN 50 / 2 Inch	DN 65 / 2½ Inch	DN 80 / 3 Inch
1	Housing bottom - DIN - with Rinsing connection	AISI303	5671 040 011-220	5671 050 011-220	5671 065 011-220	5671 080 011-220
		AISI303	5676 040 023-220	5676 050 023-220	5676 065 023-220	5676 080 023-220
	Housing bottom - Inch - with Rinsing connection	AISI303	5671 038 011-220	5671 051 011-220	5671 064 011-220	5671 076 011-220
		AISI303	5676 038 023-220	5676 051 023-220	5676 064 023-220	5676 076 023-220
2	Spindle	AISI303	5622 065 040-220	5622 065 040-220	5622 065 040-220	5622 100 040-220
3	Piston rod	AISI303	5622 065 041-220	5622 065 041-220	5622 065 041-220	5622 100 041-220
4	Bearing bush (2x)	PTFE	5622 050 006-053	5622 050 006-053	5622 065 006-053	5622 080 006-053
5	Housing insert (2x)	AISI316L	5622 050 005-040	5622 050 005-040	5622 065 005-040	5622 080 005-040
6	Piston lower - Valve insert (a),(b),(c) - Valve insert (d)	AISI316L	5621 040 005-040	5671 050 005-040	5671 065 005-040	5671 080 005-040
			5676 040 023-040	5676 050 023-040	5676 065 023-040	5676 080 023-040
7	Piston upper	AISI316L	5621 040 007-040	5621 050 007-040	5621 065 007-040	5621 080 007-040
8	Piston plate upper	AISI316L	5621 050 006-040	5621 050 006-040	5621 065 006-040	5621 080 006-040
9	Piston plate lower	AISI316L	5621 040 004-040	5621 050 004-040	5621 065 004-040	5621 080 004-040
10	Disc	AISI304	8071 064 001-020	8071 064 001-020	8071 064 001-020	8071 084 001-020
11	Hexagon nut	AISI304	8113 006 000-020	8113 006 000-020	8113 006 000-020	8113 008 000-020
12	Plain bearing	XMS	8050 015 007-156	8050 015 007-156	8050 015 007-156	8050 020 007-156
13	Split washer	AISI304	8140 006 001-020	8140 006 001-020	8140 006 001-020	8072 008 001-020
14	Hexagon screws	AISI304	8106 008 016-020	8106 008 016-020	8106 008 016-020	8106 008 016-020
	Disc DIN125	AISI304	-	-	-	-
15	Lantern					
	- Valve insert (a), (d)	AISI304	5624 040 008-021	5624 050 008-021	5624 065 008-021	5624 080 008-021
	- Valve insert (b)	AISI304	5624 040 515-021	5624 050 515-021	5624 065 515-021	5624 080 515-021
	- Valve insert (c)	AISI304	5624 040 517-021	5624 050 517-021	5624 065 517-021	5624 080 517-021
16	Valve lift stop	AISI303	5622 040 009-220	5622 050 009-220	5622 065 009-220	5622 080 009-220
17	pneumatic actuator	AISI304	5620 065 000-021	5620 065 000-021	5620 065 000-021	5620 100 000-021
D13	O-ring	NBR	2304 012 020-055	2304 012 020-055	2304 012 020-055	2304 012 020-055
K	Cap	AISI303	5622 100 071-220	5622 100 071-220	5622 100 071-220	5622 100 071-220
LA1	One-way restrictor	-	8218 001 020-015	8218 001 020-015	8218 001 020-015	8218 001 020-015
LA3	Rapid action hose coupling	-	8217 000 004-015	8217 000 004-015	8217 000 004-015	8217 000 004-015
Sp1	Screwed socket: Rinsing connection M14x1,5	AISI303	5624 065 506-220	5624 065 506-220	5624 065 506-220	5624 100 506-220
Sp2	Screwed socket: Rinsing connection DN15	AISI303	5624 065 514-020	5624 065 514-020	5624 065 514-020	5624 100 514-020
VG	(DIN) Housing SS - S	AISI316L	5621 040 001-041	5621 050 001-041	5621 065 001-041	5621 080 001-041
	(DIN) Housing S - S		5622 040 001-041	5622 050 001-041	5622 065 001-041	5622 080 001-041
	(DIN) Housing S - SS		5623 040 001-041	5623 050 001-041	5623 065 001-041	5623 080 001-041
	(DIN) Housing SS - SS		5624 040 001-041	5624 050 001-041	5624 065 001-041	5624 080 001-041
	(Inch) Housing SS - S	AISI316L	5661 038 001-041	5661 051 001-041	5661 064 001-041	5661 076 001-041
	(Inch) Housing S - S		5662 038 001-041	5662 051 001-041	5662 064 001-041	5662 076 001-041
	(Inch) Housing S - SS		5663 038 001-041	5663 051 001-041	5663 064 001-041	5663 076 001-041
	(Inch) Housing SS - SS		5664 038 001-041	5664 051 001-041	5664 064 001-041	5664 076 001-041
VK	Clamp coupling (2x)	AISI304	2122 065 100-020	2122 065 100-020	2122 080 100-020	2122 115 100-020

**Spare parts list**

Double seat valve DN 100-150 / 4 Inch / 6 Inch

Pos	Designation	Material	DN 100 / 4 Inch	DN 125 / -	DN 150 / 6 Inch
1	Housing bottom - DIN - with Rinsing connection	AISI303	5671 100 011-220	5671 125 011-220	5671 150 011-220
		AISI303	5676 100 023-220	5676 125 023-220	5676 150 023-220
	Housing bottom - Inch - with Rinsing connection	AISI303	5671 101 011-220	-	5671 152 011-220
		AISI303	5676 101 023-220	-	5676 152 023-220
2	Spindle	AISI303	5622 100 040-220	5622 150 040-220	5622 150 040-220
3	Piston rod	AISI303	5622 100 041-220	5622 150 041-220	5622 150 041-220
4	Bearing bush (2x)	PTFE	5622 100 006-053	5622 125 006-053	5622 150 006-053
5	Housing insert (2x)	AISI316L	5622 100 005-040	5622 125 005-040	5622 150 005-040
6	Piston lower - Valve insert (a),(b),(c) - Valve insert (d)	AISI316L	5671 100 005-040	5671 125 005-040	5671 150 005-040
			5676 100 023-040	5676 125 023-040	5676 150 023-040
7	Piston upper	AISI316L	5621 100 007-040	5621 125 007-040	5621 150 007-040
8	Piston plate upper	AISI316L	5621 100 006-040	5621 125 006-040	5621 150 006-040
9	Piston plate lower	AISI316L	5621 100 004-040	5621 125 004-040	5621 150 004-040
10	Disc	AISI304	8071 084 001-020	8071 105 001-020	8071 105 001-020
11	Hexagon nut	AISI304	8113 008 000-020	8113 010 000-020	8113 010 000-020
12	Plain bearing	XMS	8050 020 007-156	8050 020 007-156	8050 020 007-156
13	Split washer	AISI304	8072 008 001-020	-	-
14	Hexagon screws	AISI304	8106 008 016-020	8106 008 025-020	8106 008 025-020
	Disc DIN125	AISI304	-	8071 084 001-020	8071 084 001-020
15	Lantern - Valve insert (a), (d)	AISI304	5624 100 008-021	5624 125 008-021	5624 150 008-021
	- Valve insert (b)	AISI304	5624 100 515-021	5624 125 515-021	5624 150 515-021
	- Valve insert (c)	AISI304	5624 100 517-021	5624 125 517-021	5624 150 517-021
16	Valve lift stop	AISI303	5622 100 009-220	5622 125 009-220	5622 150 009-220
17	pneumatic actuator	AISI304	5620 100 000-021	5620 150 000-021	5620 150 000-021
D13	O-ring	NBR	2304 012 020-055	2304 012 020-055	2304 012 020-055
K	Cap	AISI303	5622 100 071-220	5622 100 071-220	5622 100 071-220
LA1	One-way restrictor	-	8218 001 020-015	8218 001 020-015	8218 001 020-015
LA3	Rapid action hose coupling	-	8217 000 004-015	8217 000 004-015	8217 000 004-015
Sp1	Screwed socket:Rinsing connection M14x1,5	AISI303	5624 100 506-220	5624 150 506-220	5624 150 506-220
Sp2	Screwed socket:Rinsing connection DN15	AISI303	5624 100 514-020	5624 150 514-020	5624 150 514-020
VG	(DIN) Housing SS - S	AISI316L	5621 100 001-041	5621 125 001-041	5621 150 001-041
	(DIN) Housing S - S		5622 100 001-041	5622 125 001-041	5622 150 001-041
	(DIN) Housing S - SS		5623 100 001-041	5623 125 001-041	5623 150 001-041
	(DIN) Housing SS - SS		5624 100 001-041	5624 125 001-041	5624 150 001-041
	(Inch) Housing SS - S	AISI316L	5661 101 001-041	-	5661 152 001-041
	(Inch) Housing S - S		5662 101 001-041	-	5662 152 001-041
	(Inch) Housing S - SS		5663 101 001-041	-	5663 152 001-041
	(Inch) Housing SS - SS		5624 101 001-041	-	5664 152 001-041
VK	Clamp coupling (2x)	AISI304	2122 125 100-020	2122 150 100-020	2122 200 100-020

## Wear part sets EPDM

Pos	Designation	Material	DN40	DN50	DN65	DN80	DN100	DN125	DN150
			1½ Inch	2 Inch	2½ Inch	3 Inch	4 Inch	-	6 Inch
	VTS EPDM (A) - Standard	EPDM a)	5670 040 739-020	5670 050 739-020	5670 065 739-020	5670 080 739-020	5670 100 739-020	5670 125 739-020	5670 150 739-000
		EPDM b)	5670 040 739-000	5670 050 739-000	5670 065 739-000	5670 080 739-000	5670 100 739-000	5670 125 739-000	5670 150 739-000
	VTS EPDM (B) - rinsing connection upper	EPDM a)	5670 040 769-020	5670 050 769-020	5670 065 769-020	5670 080 769-020	5670 100 769-020	5670 125 769-020	5670 150 769-000
		EPDM b)	5670 040 769-000	5670 050 769-000	5670 065 769-000	5670 080 769-000	5670 100 769-000	5670 125 769-000	-
	VTS EPDM (C) - rinsing connection lower	EPDM a)	5670 040 799-020	5670 050 799-020	5670 065 799-020	5670 080 799-020	5670 100 799-020	5670 125 799-020	5670 150 799-000
		EPDM b)	5670 040 799-000	5670 050 799-000	5670 065 799-000	5670 080 799-000	5670 100 799-000	5670 125 799-000	-
D1	Shaft seal (2x)	EPDM	5622 050 010-069	5622 050 010-069	5622 065 010-069	5622 080 010-069	5622 100 010-069	5622 125 010-069	5622 150 010-069
D2	O-ring (4x)	EPDM	2304 069 026-159	2304 069 026-159	2304 082 026-159	2304 098 035-159	2304 117 035-159	2304 142 035-159	2304 177 035-170
D3	O-ring	EPDM	2304 026 015-170	2304 026 015-170	2304 029 015-170	2304 042 020-170	2304 036 020-170	2304 036 020-170	2304 036 020-170
D4	Seal (2x)	EPDM	-	-	-	-	-	-	2304 133 053-159
D4	Seal (2x) two-parts (till 05/2016)	EPDM	5621 055 025-084	5621 055 025-084	5621 065 025-084	5621 080 025-084	5621 100 025-084	2304 113 025-084	-
D5	O-ring	EPDM	2304 041 035-159	2304 041 035-159	2304 050 035-159	2304 066 035-159	2304 085 035-159	2304 111 035-084	2304 140 035-159
D6	O-ring	EPDM	2304 038 018-170	2304 038 018-170	2304 048 020-170	2304 057 020-170	2304 076 020-170	2304 092 035-159	2304 108 035-170
D7	Headless pin	AISI316L	8112 006 050-040	8112 006 060-040	8112 006 085-040	8112 008 050-040	8112 008 085-040	8112 010 065-040	8112 010 090-040
D8	O-ring (2x)	EPDM	2304 036 035-159	2304 036 035-159	2304 036 035-159	2304 041 035-159	2304 041 035-159	2304 041 035-159	2304 041 035-159
D9	O-ring	EPDM	2304 047 035-159	2304 047 035-159	2304 057 035-159	2304 069 035-159	2304 092 035-159	2304 117 035-159	2304 142 035-159
D10	O-ring	NBR	2304 042 025-055	2304 042 025-055	2304 042 025-055	2304 046 025-055	2304 046 025-055	2304 046 025-055	2304 046 025-055
D11	O-ring (1x) (VTS B) O-ring (2x) (VTS C)	EPDM	2304 014 020-170	2304 014 020-170	2304 014 020-170	2304 014 020-170	2304 016 020-170	2304 016 020-170	2304 016 020-170
D12	O-ring (2x) (nur VTS C)	EPDM	-	2304 036 035-159	2304 054 035-159	2304 082 035-159	-	-	-
11	Hexagon nut	AISI304	8113 006 000-020	8113 006 000-020	8113 006 000-020	8113 008 000-020	8113 008 000-020	8113 010 000-020	8113 010 000-020

## Wear part sets HNBR

Pos	Designation	Material	DN40	DN50	DN65	DN80	DN100	DN125	DN150
			1½ Inch	2 Inch	2½ Inch	3 Inch	4 Inch	-	6 Inch
	VTS - HNBR (A) - Standard	HNBR a)	5670 040 729-020	5670 050 729-020	5670 065 729-020	5670 080 729-020	5670 100 729-020	5670 125 729-020	-
		HNBR b)	5670 040 729-000	5670 050 729-000	5670 065 729-000	5670 080 729-000	5670 100 729-000	5670 125 729-000	-
	VTS - HNBR (B) - rinsing connection upper	HNBR a)	5670 040 779-020	5670 065 779-020	5670 050 779-020	5670 080 779-020	5670 100 779-000	5670 100 779-020	5670 150 779-000
		HNBR b)	5670 040 779-000	5670 065 779-000	5670 050 779-000	5670 080 779-000	5670 125 779-020	5670 125 779-000	-
	VTS - HNBR (C) - rinsing connection lower	HNBR a)	5670 040 798-020	5670 050 798-020	5670 065 798-020	5670 080 798-020	5670 100 798-020	5670 125 798-020	-
		HNBR b)	5670 040 798-000	5670 050 798-000	5670 065 798-000	5670 080 798-000	5670 100 798-000	5670 125 798-000	-
D1	Shaft seal (2x)	HNBR	5622 050 010-050	5622 050 010-050	5622 065 010-050	5622 080 010-050	5622 100 010-050	5622 125 010-050	5622 150 010-050
D2	O-ring (4x)	EPDM	2304 069 026-050	2304 069 026-050	2304 082 026-050	2304 098 035-050	2304 117 035-050	2304 142 035-050	2304 177 035-050
D3	O-ring	EPDM	2304 026 015-170	2304 026 015-170	2304 029 015-170	2304 042 020-170	2304 036 020-170	2304 036 020-170	2304 036 020-170
D4	Seal (2x)	HNBR	-	-	-	-	-	-	2304 133 053-157
D4	Seal (2x) two-parts (till 05/2016)	HNBR	5621 055 025-171	5621 055 025-171	5621 065 025-171	5621 080 025-171	5621 100 025-171	2304 113 025-171	-
D5	O-ring	HNBR	2304 041 035-157	2304 041 035-157	2304 050 035-157	2304 066 035-157	2304 085 035-157	2304 111 035-157	2304 140 035-157
D6	O-ring	EPDM	2304 038 018-170	2304 038 018-170	2304 048 020-170	2304 057 020-170	2304 076 020-170	2304 092 035-159	2304 108 035-170
D7	Headless pin	AISI316L	8112 006 050-040	8112 006 060-040	8112 006 085-040	8112 008 050-040	8112 008 085-040	8112 010 065-040	8112 010 090-040
D8	O-ring (2x)	EPDM	2304 036 035-159	2304 036 035-159	2304 036 035-159	2304 041 035-159	2304 041 035-159	2304 041 035-157	2304 041 035-159
D9	O-ring	EPDM	2304 047 035-159	2304 047 035-159	2304 057 035-159	2304 069 035-159	2304 092 035-159	2304 117 035-159	2304 142 035-159
D10	O-ring	NBR	2304 042 025-055	2304 042 025-055	2304 042 025-055	2304 046 025-055	2304 046 025-055	2304 046 025-055	2304 046 025-055
D11	O-ring (1x) (VTS B) O-ring (2x) (VTS C)	EPDM	2304 014 020-170	2304 014 020-170	2304 014 020-170	2304 014 020-170	2304 016 020-170	2304 016 020-170	2304 016 020-170
D12	O-ring (2x) (nur VTS C)	EPDM	-	2304 036 035-159	2304 054 035-159	2304 082 035-159	-	-	-
11	Hexagon nut	AISI304	8113 006 000-020	8113 006 000-020	8113 006 000-020	8113 008 000-020	8113 008 000-020	8113 010 000-020	8113 010 000-020



## 10 Classification

### 10.1 Structure of Order Number

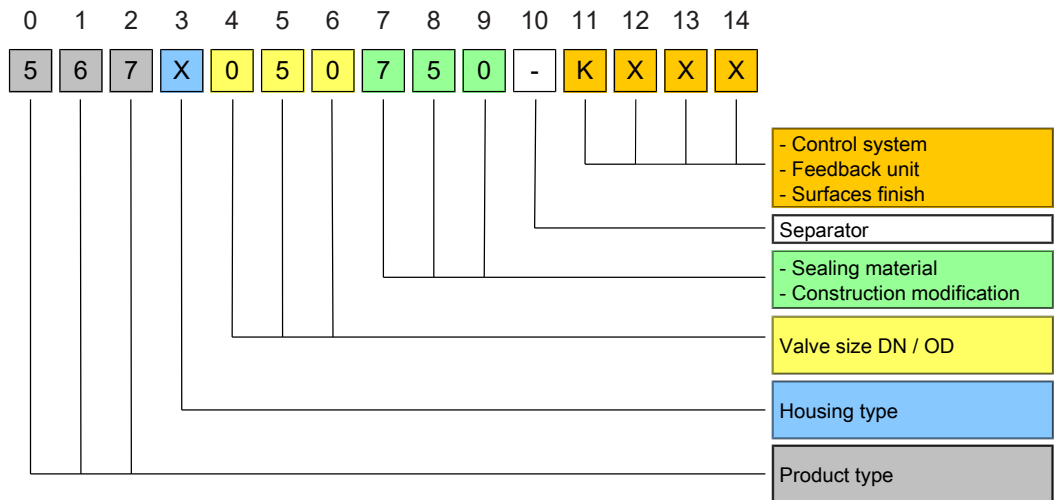





**0 - 2 Product name**

**567x xxx xxx-xxxx**

Product = Double seat valve with in product contact seals EPDM or HNBR

**3 Housing type**

**567x xxx xxx-xxxx**

Housing			3
5670	without housing (Valve insert)	-	0
5671	SS - S		1
5672	S - S		2
5673	S - SS		3
5674	SS - SS		4

**4 - 6 Valve size DN/OD**

**567x xxx xxx-xxxx**

DN	4	5	6	OD	4	5	6
DN 25	0	2	5	OD 1"	0	2	6
DN 40	0	4	0	OD 1 1/2"	0	3	8
DN 50	0	5	0	OD 2"	0	5	1
DN 65	0	6	5	OD 2 1/2"	0	6	4
DN 80	0	8	0	OD 3"	0	7	6
DN 100	1	0	0	OD 4"	1	0	1
DN 125	1	2	5	OD 5"	1	2	7
DN 150	1	5	0	OD 6"	1	5	2

**7 - 9 Material of seals & Construction modification**

**567x xxx xxx-xxxx**

Sealing material - in product contact & construction modification	7	8	9
EPDM	7	3	0
HNBR	7	2	0
EPDM - external rinsing connection upper	7	6	0

<b>Sealing material - in product contact &amp; construction modification</b>	<b>7</b>	<b>8</b>	<b>9</b>
HNBR - external rinsing connection upper	7	7	0
EPDM - external rinsing connection lower	7	9	3
HNBR - external rinsing connection lower	7	9	2
EPDM - external rinsing connection upper with cutting ring union M14x1,5 for tube Ø8x1	7	6	2
HNBR - external rinsing connection upper with cutting ring union M14x1,5 for tube Ø8x1	7	7	2

10 Separator  
 - KIESELMANN Valve

567x xxx xxx - xxxx

**11 - 14 Control system and position indication , External surface**

567x xxx xxx - xxxx

<b>Control system and position indicator</b>	<b>11</b>	<b>12</b>	<b>13</b>	<b>14</b>
Valve without control system, External surface, AISI304, blank	0	2	0	
Valve without control system, External surface, AISI304, E-polished	0	2	1	
Valve without control system, External surface, AISI304, matt	0	2	2	
Valve without control system, External surface, AISI316L, blank	0	4	0	
Valve without control system, External surface, AISI316L, E-polished	0	4	1	
Valve without control system, External surface, AISI316L, matt	0	4	2	
Valve with feedback unit (5630 005 025-000)	7	5	0	
Valve with control head SPS for double seat valves	5	x	x	
Valve with control head ASi-Bus for double seat valves	6	x	x	
Valve with control head KI-Top SPS for double seat valves	K	5	x	x
Valve with control head KI-Top ASi-Bus for double seat valves	K	6	x	x



## 11 Appendix

### 11.1 Declaration of incorporation



#### Declaration of incorporation

Translation of the original

Manufacturer / authorised representative:

KIESELMANN GmbH  
Paul-Kieselmann-Str. 4-10  
75438 Knittlingen  
Germany

Authorised representative:  
(for compiling technical documents)

Achim Kauselmann  
Paul-Kieselmann-Str. 4-10  
75438 Knittlingen  
Germany

<u>Product name</u>	<u>Function</u>
pneum. Lift actuators	Stroke movement
pneum. Rotary actuators	Rotary movement
Ball valves	Media cutoff
Butterfly valves	Media cutoff
Single seat valves	Media cutoff
Flow control valves	Control of liquefied media
Throttle valve	Control of liquefied media
Overflow valve	Definition of fluid pressure
Double seat valve	Media separation
Bellow valves	Sampling of liquids
Sampling valves	Sampling of liquids
Two way valves	Media cutoff
Tankdome fitting	Prevention of overpressure and vacuum, Tank cleaning
Safety valve	Prevention of overpressure

The manufacturer hereby states that the above product is considered as an incomplete machine in the sense defined in the Directive 2006/42/EC on Machinery. The above product is exclusively intended to be installed into a machine or an incomplete machine. The said product does not yet conform to all the relevant requirements defined in the Directive on Machinery referred to above for this reason.

The specific technical documents listed in Appendix VII, Part B, have been prepared. The Authorized Agent empowered to compile technical documents may submit the relevant documents if such a request has been properly justified.

Commissioning of an incomplete machine must not only be carried out if it has been determined that the respective machine into which the incomplete machine is to be installed conforms to the regulations set out in the Directive on Machinery referred to above.

The above product conforms to the requirements of the directives and harmonized standards specified below:

- Directive 2014/68/EU
- DIN EN ISO 12100 Safety of machinery

Knittlingen, 21.07.2017

i.V. Uwe Heisswoff  
Head of Development